

PANEL INDICATOR LEDs - Ø 8.0mm Mounting

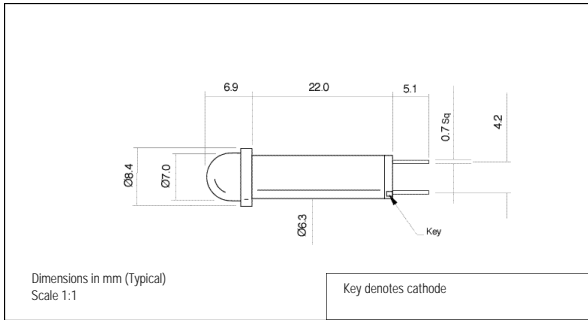

- Front panel replaceability
- Domed fresnel lens for wide angle viewing
- Sealed to IP40
- Must be used in conjunction with panel socket 907-000-00



411 SERIES

MLQ = 20

Ordering Information & Typical Technical Characteristics (Ta = 25°C)

Mean Time Between Failure = 90,000 Hours. Luminous intensity figures refer to the unmodified discrete LED.

PART NUMBER	COLOUR	LENS	VOLTAGE DC Vopr	CURRENT DC Iopr	LUMINOUS INTENSITY Iv@20mA	WAVE LENGTH p	VIEWING ANGLE	OPERATING TEMP Topr	STORAGE TEMP Tstg
HIGH INTENSITY									
411-501-04	Red	Coloured Diffused	1.9*	20	2750	660	Wide	0 ~ +85	0 ~ +85
411-521-04	Yellow		2.0*	20	4500	590			
411-532-04	Green		3.4*	20	6000	525			
411-930-04	Blue		3.4*	20	2000	470			
411-997-04	White		3.4*	20	3000	•			
411-501-22	Red		24	20	2750	660			
411-521-22	Yellow		24	20	4500	590			
411-532-22	Green		24	20	6000	525			
411-930-22	Blue		24	20	2000	470			
411-997-22	White		24	20	3000	•			
UNITS			Vdc	mA	mcd	nm		°C	°C

* = Voltage DC for 20mA product is Vf@20mA, not Vopr

• = Typical emission colour: x=0.31, y=0.32. Colour temperature 8000K. Intensities (Iv) and colour shades of white (x,y co-ordinates) may vary between LEDs within a batch.

Please note - This product is also available at 5, 12 and 28Vdc. AC versions are also available. Please contact our Sales department for further details.

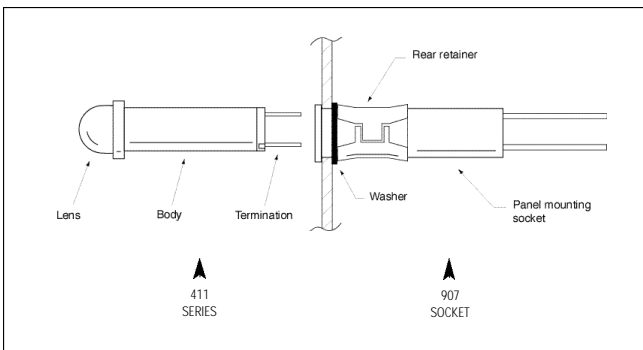

SAMPLES AVAILABLE

